

Toleranser för icke toleranssatta bearbetningsmått:
 Tolerances for untoleranced machining measures:
 1-6-30-120-400-1000-2000-4000-8000
 ±0,1 | ±0,2 | ±0,3 | ±0,5 | ±0,8 | ±1,2 | ±2 | ±3
 I övrigt se
 Otherwise see K-20021-1 medel (ISO 2768-1;1989 medium)

1000

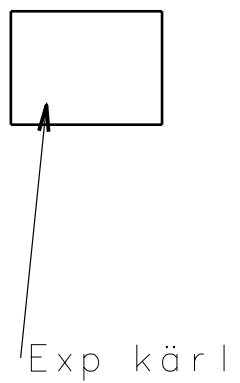
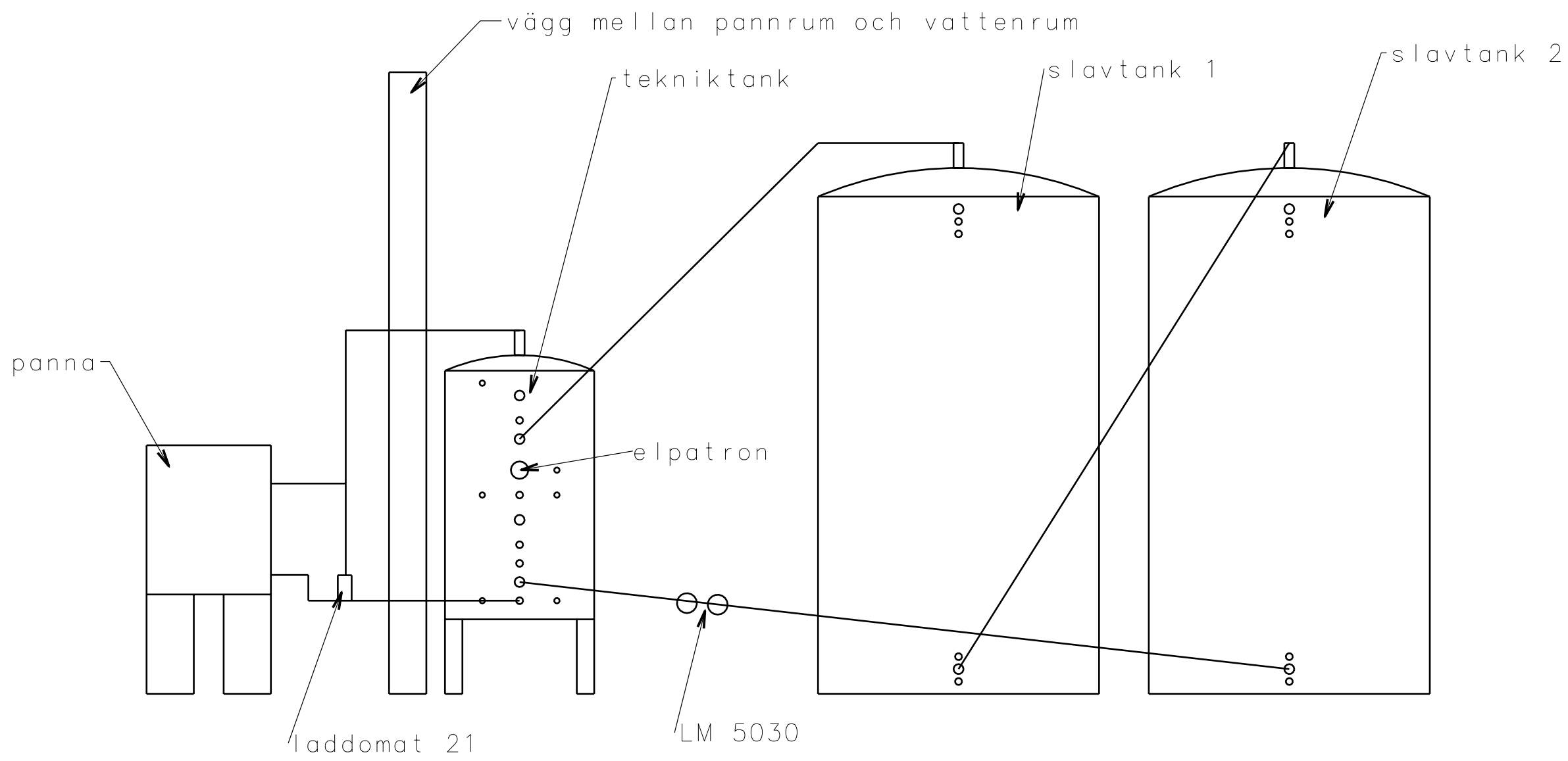

Article No.		Material		Blank	
Prepared by Anders Carlsson	In principle conforming to	Accepted for prod.	GS with the same Doc.No. yes <input type="checkbox"/>	Scale	
Checked	Respons. dept. STT	Archive	Title		
Approved	Date	Weight	Langu.		
Revision -	Document kind TC104	HG	Plant or type		No. of sh. 1
[Redacted]			Document No.		Sheet 1

TMPL 103:1	Rev.	Specification	Date	Sign.
------------	------	---------------	------	-------

Created with CCD